

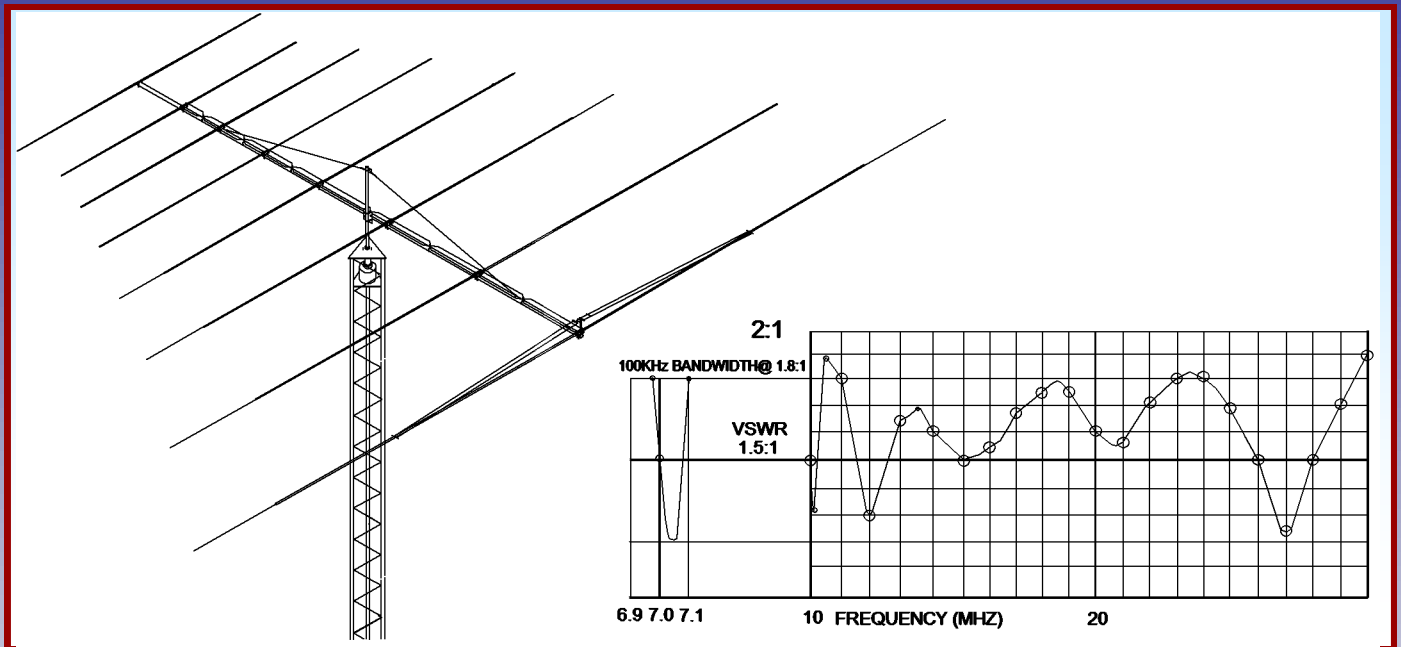

M2 Antenna Systems, Inc.

Model No: 7&10-30LP8



SPECIFICATIONS:

Model	7&10-30LP8 "Skip log"	Input Connector	SO-239, Others avl.
Frequency Range	10-30 MHz Continuous and a separate frequency tunable from 6.6 to 8.0 MHz	Power Handling	3 Kw Higher avl.
*Gain free space / 65'	5.2 dBi / 10.5 dBi 10-30	Boom Length / Dia	29.5' / 3.0 x .125 Wall
*Gain free space / 65'	2 dBi / 6.5 dBi 6.6-8.0	Maximum Element Length	49'
Front to back.....	15 dB 10-30 MHz	Turning Radius:	28'
Beamwidth	E=70° Typical	Mast Size	2" to 3" Nom.
Feed Impedance.....	50 Ohms Unbalanced	Wind area / Survival.....	13.0 Sq. Ft. / 100 MPH
Maximum VSWR	2.0:1	Weight / Ship Wt.	110 Lbs. / 125 Lbs.

***Subtract 2.14 from dBi for dBd**

FEATURES:

This special "skip frequency" hybrid log periodic is a rugged versatile performer designed for years of trouble free service. For the amateur radio operator it covers **SEVEN** Amateur Bands with high efficiency and no traps! Machined aluminum element to boom clamps and solid fiberglass rod center insulators are just a few of the unique structural features in this remarkable antenna.

The 7&10-30LP8 is a single, economical antenna system that matches up with today's modern solid state equipment and keeps you competitive on every frequency on every band instantaneously. Low wind load and less weight put less demands on the rotator and tower structures.

Maritime, Government, Commercial, MARS, Scientific and Amateur users are finding the 7&10-30LP8 reliably fills a variety of communication requirements. When properly installed at 65 feet or higher this eight element antenna is a world wide, world-class performer. Solid electrical and structural design will maintain communications when other antennas have long since faded into the noise.

7&10-30LP8 ASSEMBLY MANUAL

BEFORE YOU BEGIN: Look over the DIMENSION SHEET, HARDWARE AND ELEMENT ASSEMBLY DRAWINGS to get familiar with the various parts of the log periodic. Tools handy for assembly process: screwdriver, 11/32, 7/16, 1/2, 9/16 and 5/8" spin-tites, end wrenches and/or sockets, measuring tape.

Two containers of zinc paste (Penetrox, Noalox, or equiv.) has been provided to enhance and maintain the quality of all electrical junctions on this antenna. Apply a thin coat wherever two pieces of aluminum come in contact or any other electrical connections are made. It is also useful on screw and bolt threads as an ANTI SEIZE compound.

Note: Element Overhead Support has been upgraded. Please see pages titled: Element Overhead Support Upgrade for more details before you start your assembly process.

1. ASSEMBLING THE ELEMENT MOUNTING PLATE. SEE HARDWARE DRAWINGS.
The mounting plates fit THREE diameters of fiberglass rod insulators. Pair them up as follows:
 - A. The two 3" x 6" x 1/2" plates milled with a 5/8" radius channel are for ELEMENT #1 (the rear linear loaded element) and clamps a 1-1/4" x 24" fiberglass rod.
 - B. The four other 3" x 6" x 1/2" mounting plates, with a 1/2" radius channel, are for ELEMENTS #2 AND #3 and clamps 1" x 24" fiberglass rods.
 - C. Elements #4 through #7 use a single 2-1/2" x 4" x 3/8" plate and a matching rectangular 1-3/4 x 4" x 1/4" cap plate, and clamps 7/8" x 29-3/4" fiberglass rods. (Elements #4, 5, 6, and 7 use a single bottom cradle each).
 - D. Element #8, the front director element mounts differently, using two clamp cradles as described in step 13.
 - E. Start by assembling the 1-1/4" rod MOUNTING PLATES together with 1/4-20 x 2-1/2" bolts to the four outer holes. Add the 1/4-20 locknuts finger tight. Slip in the 1-1/4" X 24" fiberglass rod and rotate until the element mounting holes are vertical. ***Center the rod and tighten the hardware EVENLY, so the plates are parallel and the same amount of threads are showing through all the locknuts.***
2. The Element #1 mounting plate set also requires a 1" square x 24" WELDED VERTICAL SUPPORT POST to anchor element support and the linear loading lines. (SEE ELEMENT #1 OVERHEAD SUPPORT UPPGRADE) Orient the post top plates so they will extend over the element center. Install 1/4-20 x 3-3/4" bolts through the post and mount it to the middle two holes of the mount plate and secure with 1/4-20 locknuts. Install two turnbuckles in the plate holes and extend the turnbuckles so one thread on each end appears inside the body in preparation for later steps.
3. Assemble the remaining element clamp plate sets to fiberglass rods. The hardware is as follows: The mounting plate pairs for ELEMENTS #2 & #3 each require (6) 1/4-20 x 2-1/2" bolts and locknuts and a 1" x 24" fiberglass rod. The next three elements (#4 5, & 6) each require (4) 1/4-20 x 1-3/4" bolts and locknuts.
4. For Element #7 attach the Balun Bracket to the top two holes on one of the element clamp plates using two 1/4-20 x 1-3/4" bolts. Insert two 1/4-20 x 1-1/2" bolts in the bottom two holes. Insert the remaining 7/8" x 29-3/4" fiberglass rod and secure all 1/4-20 hardware. See the drawing HARDWARE ARRANGEMENT FOR ELEMENT #7.

7&10-30LP8 ASSEMBLY MANUAL

5. Now slide a POLY DISC INSULATOR (1-1/4", 1" or 7/8" internal Dia.) onto each end of ALL fiberglass rods and push them up against the mounting plates. The disc insulators are sometimes a very tight fit on the rods. If so, place them in hot water a few moments before installation. Set mounting plates assemblies aside for later.
6. #2 THROUGH #7 ELEMENT ASSEMBLY.
Refer to the DIMENSION SHEET. All the tubing sections with swaged (necked down) ends are 5' (60") long . Only the element tip sections are different lengths. The correct hardware to join the various sizes are as follows:
For 1-1/2" to 1-1/4" tubing uses 8-32 x 1-3/4" screws.
For 1-1/4" to 1" tubing use 8-32 x 1-1/2" screws.
For 1" to 3/4" tubing use 8-32 x 1-1/4" screws.
For 3/4" to 1/2" tips use 5/8" compression clamp (see compression clamp & tip assembly sheet).
Locknuts have been provided for all the element assembly screws. Tighten the nuts until the joint doesn't move when wiggled or shook. The element butt section closest to the boom always has one hole located at the butt for a 1/4-20 bolt, 1/2" longer than the element section diameter. Loosely install the bolts at this time as they must be removed later while installing the elements to the fiberglass rod insulators. Assemble elements #2 through #6. Pair up element halves and set aside.
7. ELEMENT #1 ASSEMBLY. Refer to Element #1 assembly detail & Element #1 Tuning Details.
 - A. Assemble the 1" x 60" and the 3/4" x 60" outer element sections first. Connect the two sections with 8-32 x 1-1/4" screws and locknuts.
 - B. Prepare the LINEAR LOADING DUAL SUPPORT ARMS (1" central hole) with (4) 8-32 x 1/4" Allen head SET SCREWS (5/64 Allen wrench supplied), two 8-32 x 1-1/2" screws and locknuts, and a white poly STEPPED INSULATOR (into 3/4" hole). Slide a DUAL SUPPORT ARM on each 1" section and position 27" from the butt end. Orient with the large stepped side of insulator towards element tip and arm in mirror image between element halves. Add the element overhead support clamp 1" past the dual support arm on the out portion of the element. WHEN THESE 1" ELEMENT SECTIONS ARE FIT INTO THE 1-1/4" DIAMETER ELEMENT SECTION, ORIENT THE STRAIGHT SIDE OF THE DUAL SUPPORT ARMS UP.
 - Prepare two ABS LL SUPPORT INSULATORS. These are flat, black 1" x 6" ABS bars. Attach them to the short 3/8" x 1-1/4" x 3" Linear Loading Support arm with 1" hole. Use 8-32 x 1" screws and locknuts. Slide these on the 1" element sections and position at 3" from the butt. Orient the insulators in the same plane as the Dual support arms. Secure with 8-32 x 1-1/2" screws and locknuts.
 - C. Prepare the (4) 3/4" hole LINEAR LOADING ARMS with two 8-32 x 1-1/4" screws and locknuts and a 1/2" x 1-1/2" white poly linear loading support arms (centered in arm). Slide two arms onto each 3/4" element section. Do not position at this time.
 - D. Prepare the (2) 1/4" x 1/2" LINEAR LOADING ARMS with two 8-32 x 1" screws and locknuts and a 1/2" x 1" white poly Linear Loading Insulators. Slide arms onto the 1/2" x 67" element tip sections. Install the 1/2" element tip sections to the 3/4" element section using the 5/8" compression clamp (see compression clamp & tip assembly sheet).
 - E. Install the 1-1/4" x 60" element sections to the outer element assemblies completed in steps A through D. Secure with 8-32 x 1-1/2" screws and locknuts. Set element assemblies aside for now.

7&10-30LP8 ASSEMBLY MANUAL

F. Prepare the (2) 1-1/2" PHASING LINE CLAMPS BLOCKS AND CAP PLATES by applying a little paste to the channels on each face. Then loosely assemble plates to blocks, channel to channel, with 1/4-20 x 1" FLATHEAD SCREWS AND LOCKNUTS. Loosely install an 8-32 x 2" screw and locknut through block clamp fingers. Apply zinc paste to the last inch of the 1-1/2" element butts and then install a PHASING LINE CLAMP BLOCK assembly onto the end of each element butt, small clamp plate oriented to element butt.

G. Slide a 1-3/8" x 23-13/16" sleeve onto the 1-1/4" fiberglass rod (held by element mounting plates) and align the 1/4" holes. Carefully slide a 1-1/2" x 60" element sections onto this assembly and align all holes. Insert a 1/4-20 x 2" bolt and secure with 1/4-20 locknut. Repeat for the other element half. Now position each phasing line clamp block about 1/4" away from the disc insulator and with the 8-32 element clamp screw oriented to the bottom. Tighten screw and locknut just enough to keep the block from moving (it will be repositioned when phasing lines are installed). Repeat for other element half. Now add the outer element assemblies to the 1-1/2" sections using 8-32 x 1-3/4" screws and locknuts.

H. Place the element on a level surface with the support post up. FROM THE ELEMENT BUTT SIDE, feed a 3/16" x 135" LINEAR LOADING ROD through the ABS LL support insulator and on to the un-insulated side of the DUAL SUPPORT ARM until 5/8" extends beyond arm. Tighten the 8-32 x 1/4" set screws. Install two SHAFT RETAINERS, one at a time, onto this rod tip and snug up to dual support arm.

NOTE: to start the RETAINER, hold the 3/8" x 3" PUSH TUBE in your hand with one end between your thumb and forefinger. Now center retainer on this end, "dish" into tube, and hold in place with the same thumb and forefinger. Grasp the linear loading rod near the end with your other hand and firmly push the retainer onto the rod.

In the same way, feed another 135" LINEAR LOADING ROD through the ABS LL support insulator and on through the white poly stepped insulator until 5/8" extends beyond insulator. Install two SHAFT RETAINERS, one at a time, onto this rod tip and snug up to insulator. Install two 8-32 x 1/4" set screws into a SPLICE BLOCK and install block on 1/2" rod tip up against the retainers. Tighten set screw. Repeat for other element half.

I. Slide a 3/16" x 144" rod through the white poly linear loading insulators on the 3 arms beyond the dual support arm. Insert the inner rod end into splice block at the dual support arm and tighten set screw. SEE THE FREQUENCY CHART on the ELEMENT #1 LINEAR LOADED TUNING DETAILS and select the desired center frequency for Element #1. Cut this outer linear loading rod to the desired dimension. Position the outermost linear loading arm about 6" from the tip. Space the other arms to support the rod at equal intervals. Then tighten all clamp screws. Repeat for other element half.

J. Next, pre-assemble both pair of LINEAR LOADING SHORTING BARS using (5) 8-32 x 7/8" screws and locknuts. NOTE: THE BARS ARE NOT SYMETRICAL IN THE CENTER GROOVES. Now pass about 4" of HPTG-1200 through the CENTER groove and around the strain relief back through the offset grooves so you have about 2-1/2" of cable end coming back for later clamping. CONSULT THE FREQUENCY CHART and use a tape measure to mark each rod at the CORRECT "A" DIMENSION measured as shown. Slide a shorting bar set onto the rod ends and position the shorting bar clamps at your marks. Level the bars; equalize the rod tension and begin tightening the outer screws. Once everything is straight and aligned, tighten all 5 screws. Repeat for the other side.

7&10-30LP8 ASSEMBLY MANUAL

NOTE: DO NOT TRIM OFF THE EXCESS ROD BEYOND THE SHORTING BAR TO 5", UNTILL FINAL TUNING IS ACHIVED. IF OPERATION IS DESIRED BELOW 6.950 MHZ, THE FULL LENGTH OF THE LINEAR LOADING RODS MAY BE REQUIRED.

- K. Cut the 30 ft. phyllstrand into to equal length and rout though the element support clamps and pull tight. (see the self locking method shown on the addendum) Rout the other end of the cable through the thimble and upper turnbuckles and wire clips and pull tight and tighten the clips, equally tension the cables using the turnbuckle. To check your tension, lift the element up at the center and note the element droop. Each element should droop 10" to 16" at the tip.
- L. Now rout the linear loading phyllstrand through the lower turn buckles and thimbles and add the wire clips. Pull the cable though and tighten the wire clips. Use the turnbuckles to tension them just to slightly help the main element supports.

This completes Element # 1 assembly, set aside for now.

8. BOOM ASSEMBLY

Wipe off the swaged end of the front 180" boom section and apply a small amount of light oil. Gently insert it into one drilled end of the straight 180" boom section. Align the holes, install the 1/4-20 x 3-1/2" bolts and locknuts, and tighten.

NEXT Install the 3/8" EYEBOLTS to the outer ends of the boom, securing with stainless 3/8-16 nuts and lock washers. Align the eyes parallel with the boom and tighten.

9. Orient the boom with the eyebolts "up". The boom end with the eyebolt at 52" from end is the "REAR". Using a tape measure and a marking pen or masking tape, place a mark 1/2" in from the **rear** of the boom. This will be where you position the back edge of the clamp plate for element #1. Now measure forward 78-3/4" from that mark and make another mark. Identify this position as element #2. Continue marking the locations of all the elements using the element spacing figures given on the Dimension Sheet.
10. Attach Element #1, the linear loaded element, to the boom. For ease of element installation, support the boom about 3' above ground, eyebolts "up." Loosely attach two BOTTOM CRADLES to the bottom of the clamp plates using the 1/4-20 x 2-3/4" hardware. Slip Element #1 over the rear of the boom, placing the back edge of the rear plate on your first mark. ALIGN the elements horizontal perpendicular to the eyebolts and tighten bolts **EVENLY** and firmly. Use element #1 as the element alignment reference.
11. Mount the next element clamp assemblies in element position #2, and #3. First place the clamp plates on the boom at the mark and then add the two bottom cradles and 1/4-20 x 2-3/4" bolts. Align with the first element clamp and tighten **gently**. FINAL ALIGNMENT of all the elements will be done after the elements are mounted.
12. Mount the clamp plates with the 7/8" diameter fiberglass rods, again position each clamp at the mark, aligning with the first clamp and tightening **gently**. Only one cradle is required.
13. Now mount the DIRECTOR. Insert the 3/4" x 60" element sections into the 7/8" x 30" center tube, align the holes and use two 1/4-20 x 5" bolts. Install an inverted cradle onto the bolts and up against the 7/8" sleeve section. Place this assembly on the boom. Add the bottom cradle and locknuts. Align the completed element with the element #1 at the other end of the boom and tighten the nuts. Install the Director's 1/2" tip sections with 5/8" compression clamps.

7&10-30LP8 ASSEMBLY MANUAL

14. MOUNTING ELEMENT HALVES #2 THROUGH #6. REFER TO DIMENSION SHEET AND HARDWARE ASSEMBLY DRAWINGS.

Prior to slipping the element halves on the fiberglass insulators, apply a little **zinc oxide paste** to the last inch of each element butt. Apply a little paste to the channels in all the small PHASING LINE CLAMP CAPS and the larger PHASING LINE CLAMP. This paste inhibits corrosion and helps to assure a reliable, low loss joint for many years. Then loosely assemble plates to blocks, channel to channel, with 1/4-20 x 1" FLATHEAD SCREWS AND LOCKNUTS. Loosely install an 8-32 screw and locknut through block clamp fingers using 8-32 x 1-1/2" screws for 1" clamps and 8-32 x 1-3/4" screws for 1-1/4" clamps. Install a PHASING LINE CLAMP assembly onto the end of each element butt with small clamp cap oriented to element butt.

15. On element #2, slide 1-1/8" x 24" sleeve over the 1" fiberglass rod end and align the 1/4" holes. Then add the element half (with a 1-1/4" butt sections and a 1/2" tips sections) over the sleeve and rod, align the holes and add a 1/4-20 x 1-3/4" bolt and locknut. Tighten securely. Repeat for the other element half. Repeat for element #3 using element halves with 3/4" tips. Install element halves #4 through #7 to the 7/8" fiberglass rod insulators.

16. Now carefully align elements #2 through #8 to element #1. TIGHTEN each bottom cradle EVENLY AND SECURELY.

17. INSTALLING THE PHASING LINES. SEE DIMENSION SHEET & HARDWARE ASSEMBLY DRAWINGS

Start with the shortest set between element #6 and #7. For each set, feed the phasing lines through a 3/4" x 3" DELRIN SPACER so that the spacer sits at the crossover point between the lines. Hold the spacer in place loosely around the boom with a large nylon tie but don't tighten it yet. Adjust phasing lines so that their bends are even and the lines run parallel to the boom.

A. Apply a small amount of conductive paste to the rod ends and feed the #7 ends into the clamp block channels until 1/4" extends beyond clamp. Tighten the 1/4-20 x 1" flathead screws and locknuts on element #7. Then adjust the block assemblies flush to the disc insulators and tighten 8-32 clamp screws. Insert the other rod ends into the clamp block assemblies on element #6 but do not tighten. Continue to the next phasing line set between element #5 and #6. Apply paste and insert the ends into the clamp blocks at element #7 and NOW tighten the flathead screws and nylon ties.

While installing the phase lines, you might find that some of them will extend 1" - 2" past their respective clamp blocks. **This is OK.** You can trim them back, in order to fit flush with the clamp block faces, if you desire.

B. Continue in the same fashion tightening the hardware and nylon ties as you go.

Note the phasing lines between elements #2 and #3: The bends in this set of phasing lines are **offset**, with the **crossover point closer to element #3**. This offset is to allow for I-bolt clearance.

Note the phasing lines between elements #3 and #4: The bends in this set are **offset**, with the **crossover point closer to element #3**. This offset is to allow proper placement of the boom to mast plate.

C. Attach the 16 turn COIL to element #1 screw studs before securing phasing lines. Position coil upright, but clearing the support post and tighten the nuts. Try to keep coil tightly wound, spread no more than 5" to 6".

18. MOUNTING THE 4:1 BROAD BAND BALUN

Secure the BALUN to the BALUN BRACKET with a 2-1/2" U-bolt and cradle. Tighten nuts only enough to secure balun. **DO NOT OVER TIGHTEN - BALUN HOUSING COULD BE DAMAGED!** Position balun with the connector pointing towards the rear of the boom and leads easily reaching phasing line clamps screw studs. Now remove the 1/4" nuts from the clamp block screws. Apply some zinc paste to the lugs on the balun leads and place over each screw stud. Replace the nuts and re-tighten.

7&10-30LP8 ASSEMBLY MANUAL

19. Attach the BOOM TO MAST PLATE with the two large 3" U-bolts. Center it at the Delrin standoff between element #3 and #4. Reshape the phasing lines as needed to clear the plate by at least 1/2".
20. OVERHEAD BOOM SUPPORT SYSTEM.
 - A. Attach one end of the 5/16" Dacron cord to the rear eyebolt using two turns around the eyebolt and a series of three half hitches or equivalent knots. Finish with about 6" of cord after the knots. **Without cutting the cord, do the same at the front eyebolt.** Pull on the knots **HARD** to **SET** them. Seal ends with heat or flame to prevent fraying. Tape the excess 6" of cord back to main cord tightly with black vinyl electricians tape.
 - B. TEMPORARILY insert a 2" U-bolt through the turnbuckle plate and add two nuts so about 1/2" of the threads stick out. Insert this assembly through the top set of 2" U-bolt holes in the boom to mast plate from the boom side and add two more nuts. Open the two turnbuckles up until just **a thread or two** from each end shows **inside** the body of the turnbuckle. Hook the turnbuckles into the holes at the edge of the turnbuckle plate. Equalize the Dacron cord over the plate and cut it. Take two wraps of the cord through the eye of the rear turnbuckle, **PULL** the cord as tight as possible and make the knots as before. Repeat for the front cord section and turnbuckle. Cut off any excess over 1' long and again seal and tape back to the main cord.
 - C. Now **DISASSEMBLE** the U-bolt from the boom to mast plate. Before installation, if possible, install a short temporary mast, attach turnbuckle, and let the overhead guy system support the boom overnight. The Dacron cord **DOES NOT STRETCH UNDER THIS LOAD** but it's weave will take a **SET** and the boom may droop just a bit. If your boom droops again following final adjustments, check your knots. They may be slipping.
 - D. After final installation of the antenna, the turnbuckle plate, installed loosely with a 2" U-bolt, is raised up the mast. When the boom is straight the U-bolt is tightened. This should place the turnbuckle plate 4' to 6' above the boom. Do the final boom straightening with the turnbuckles and safety wire to preserve adjustments.
21. Install all element tip sections that may have been removed or omitted to facilitate other assembly procedures.
22. Check ALL hardware for tightness. Check ALL element sections, especially tip sections, for correct placement. Make any final adjustments to linear loading tension.
23. Attach feed line section to balun. Secure at regular intervals with tape or nylon ties.
24. When mounting this log periodic on a tower or mast with other antennas there may be interaction with other nearby antennas, particularly if they are resonant in the 7 to 30 MHz band. In general VHF and/or UHF antennas mounted for HORIZONTAL POLARITY should be at least 40 inches above or below the log antenna. Use good quality 50 Ohm feed line to feed the log and be sure your tower and rotator system can handle to wind area and weight of this antenna.

THIS COMPLETES THE ANTENNA ASSEMBLY

M² ANTENNA SYSTEMS, INC.

4402 N. SELLAND AVE.

FRESNO, CA 93722

(559) 432-8873 Fax: 432-3059

www.m2inc.com Email: sales@m2inc.com

2M4 ASSEMBLY MANUAL

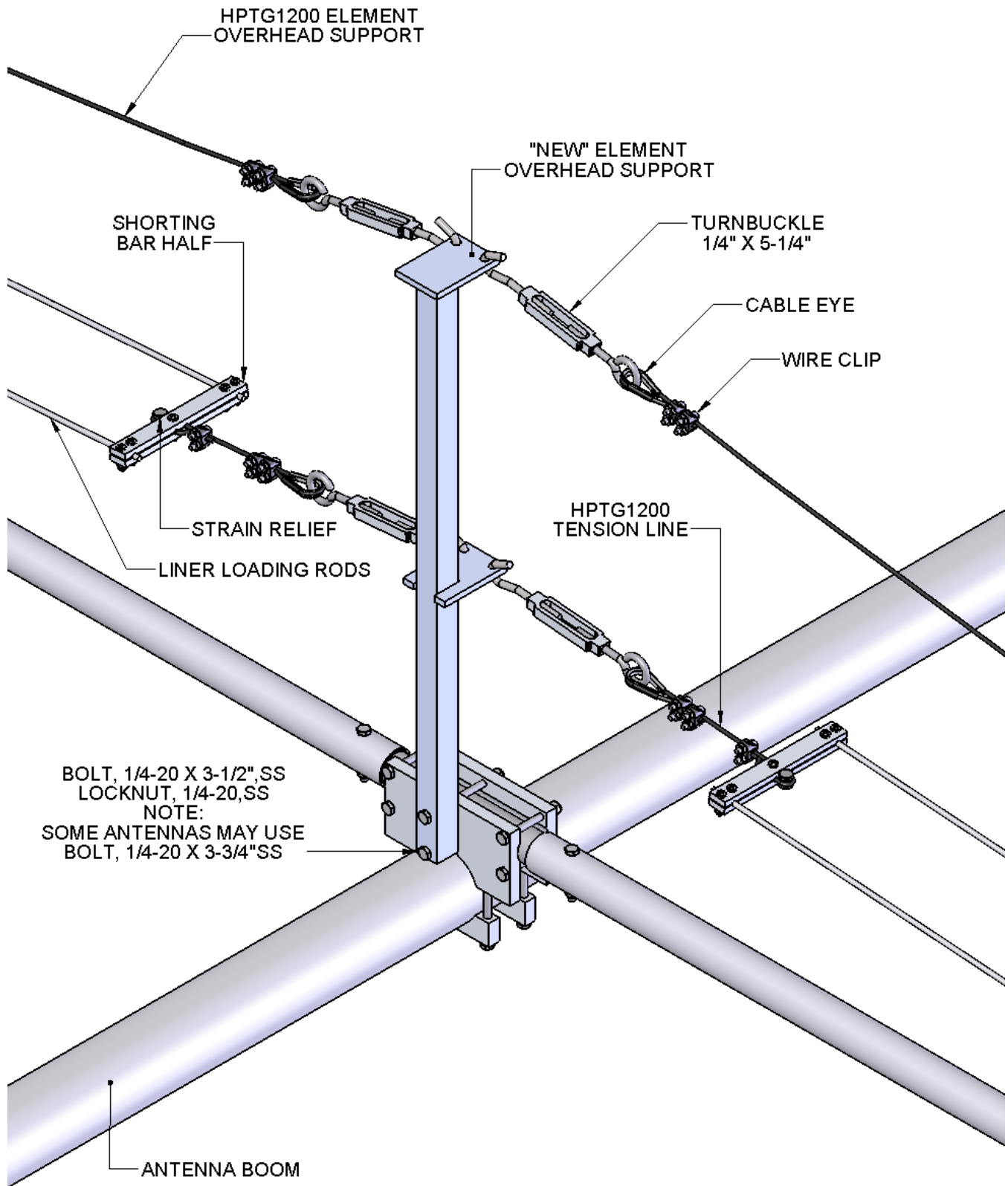

ELEMENT #1 OVERHEAD SUPPORT UPGRADE

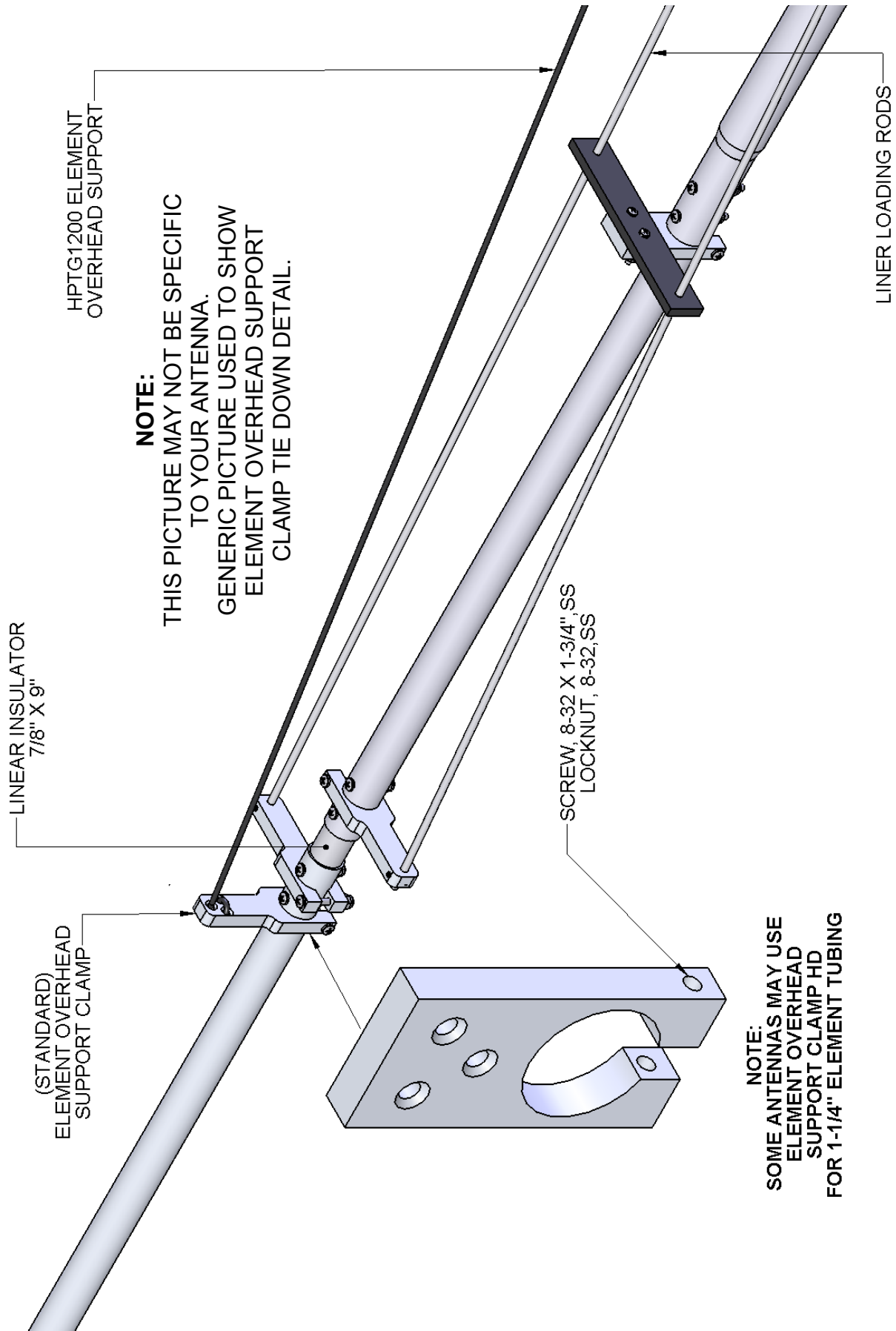

NOTE:
THIS PICTURE MAY NOT BE SPECIFIC
TO YOUR ANTENNA.
GENERIC PICTURE USED TO SHOW
ELEMENT OVERHEAD SUPPORT
CLAMP TIE DOWN DETAIL.

NOTE:
SOME ANTENNAS MAY USE
ELEMENT OVERHEAD
SUPPORT CLAMP HD
FOR 1-1/4\"/>

ELEMENT #1 ASSEMBLY DETAILS

ELEMENT #1 HARDWARE DETAIL (COIL NOT SHOWN)

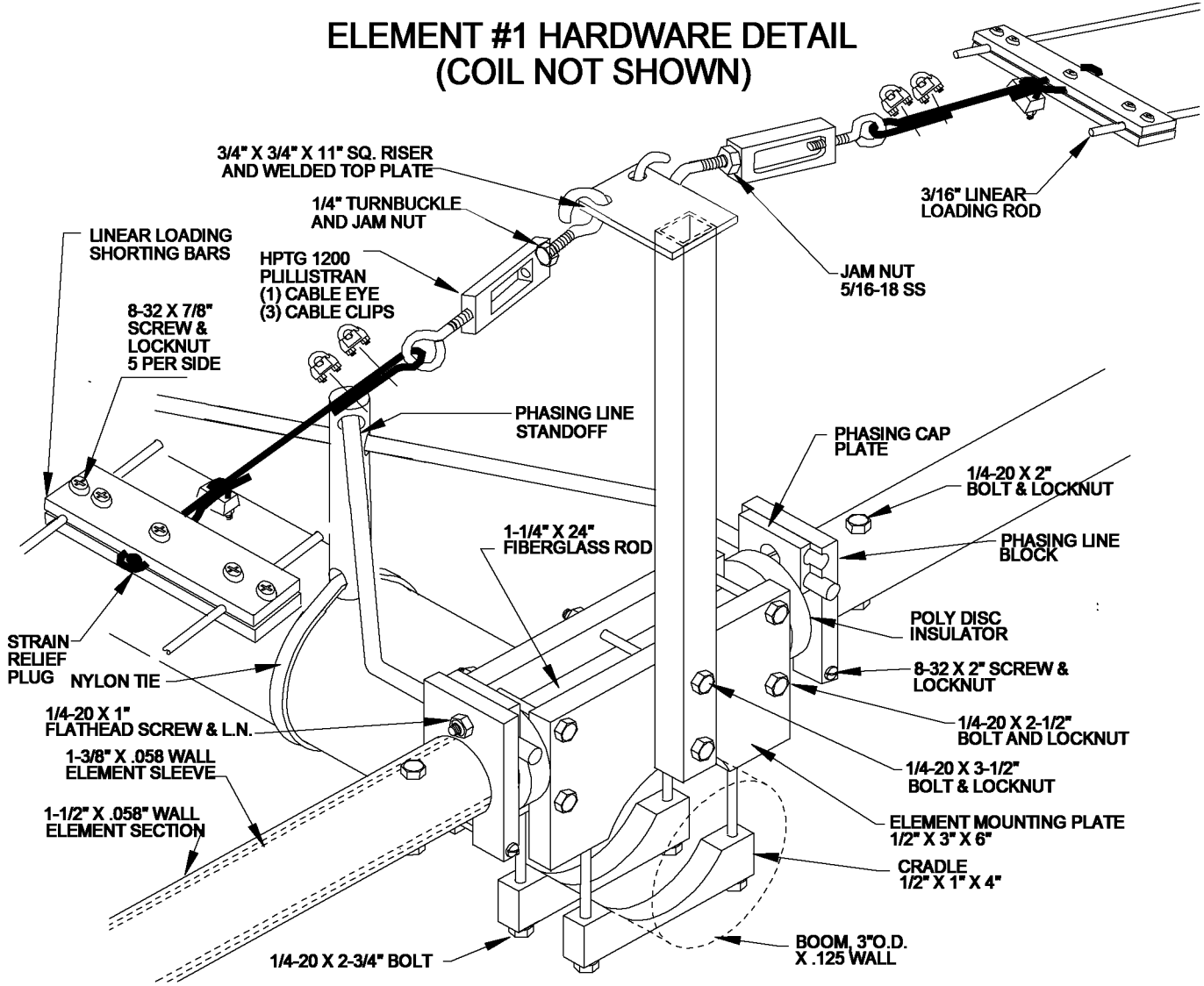

SHORTING BAR AND HPTG PHYLISTRAN ASSEMBLY DETAIL

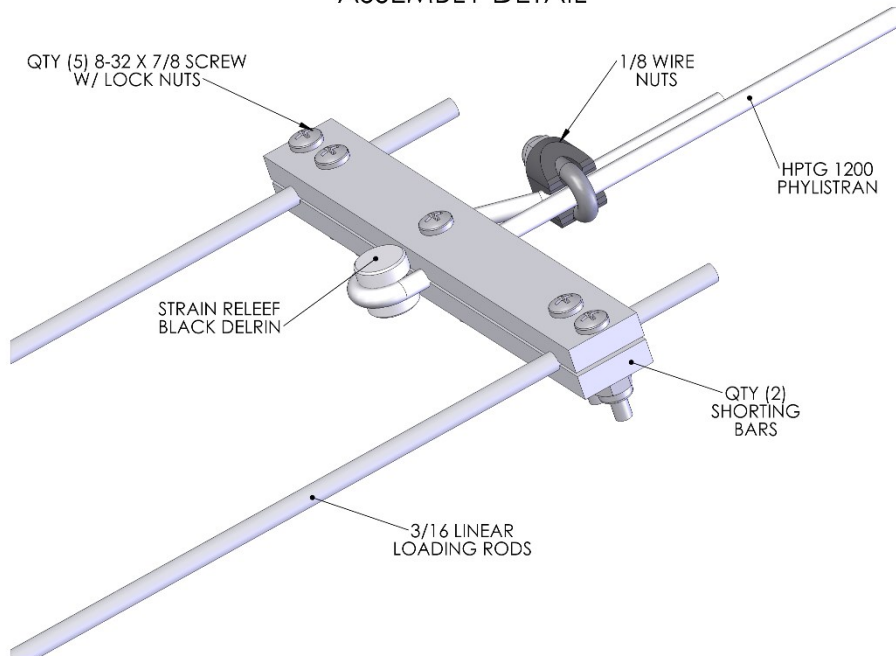

ELEMENT #1 TUNNING DETAILS

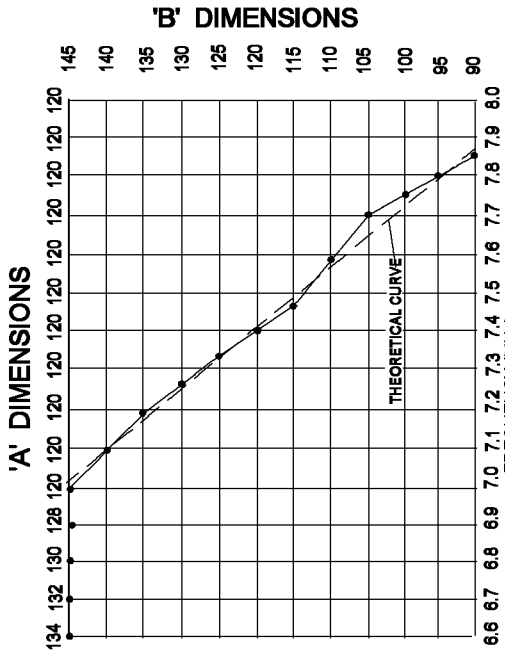

THESE POINTS WERE TAKEN FROM ACTUAL MEASUREMENTS TAKEN AT 45 FEET. FOR EXTENDED TUNING RANGE BELOW 6.6 MHz OR ABOVE 8.0 MHz, CONTACT M2 FACTORY.

DUAL SUPPORT ARM DETAIL

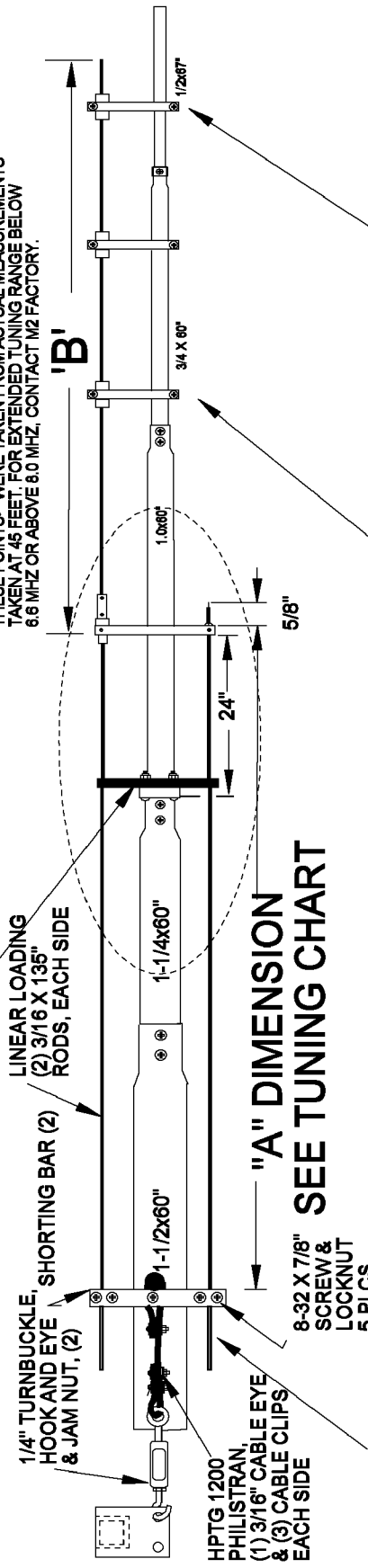
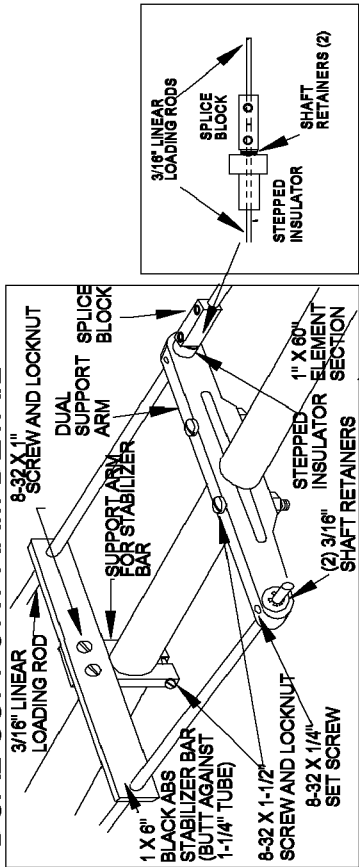

"A" DIMENSION SEE TUNING CHART

TRIM OFF EXCESS 3/16 ROD TO 5" PAST SHORTING BAR

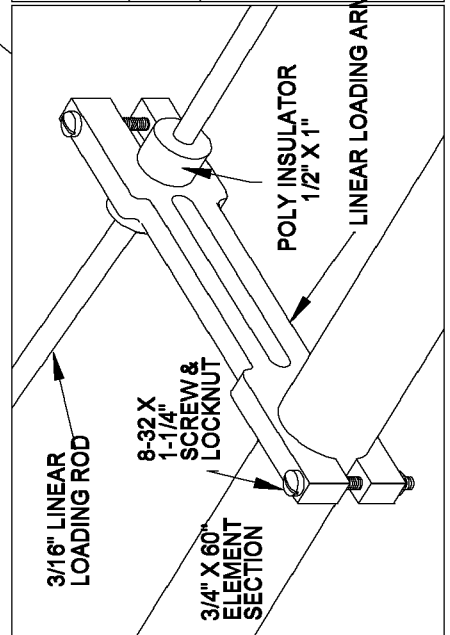
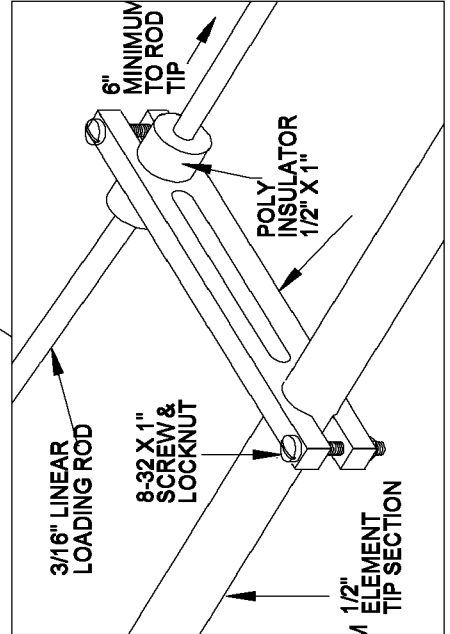

7&10-30LP8: ELEMENT #1 LINEAR LOADING TUNING DETAILS

7&10-30LP8 ASSEMBLY DETAILS

ELEMENT #2 & #3 HARDWARE DETAIL

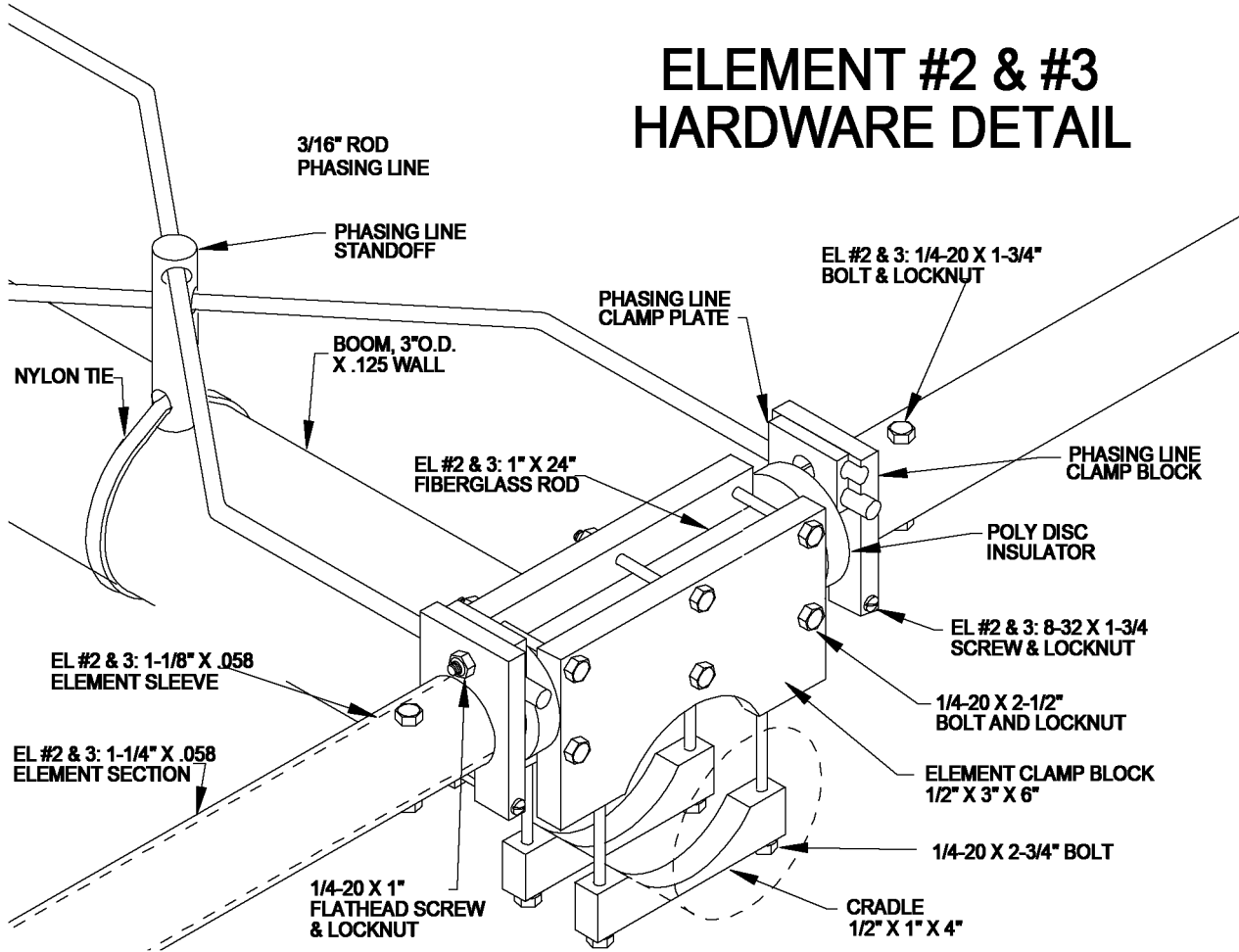

ELEMENT #4 - #6 HARDWARE DETAIL

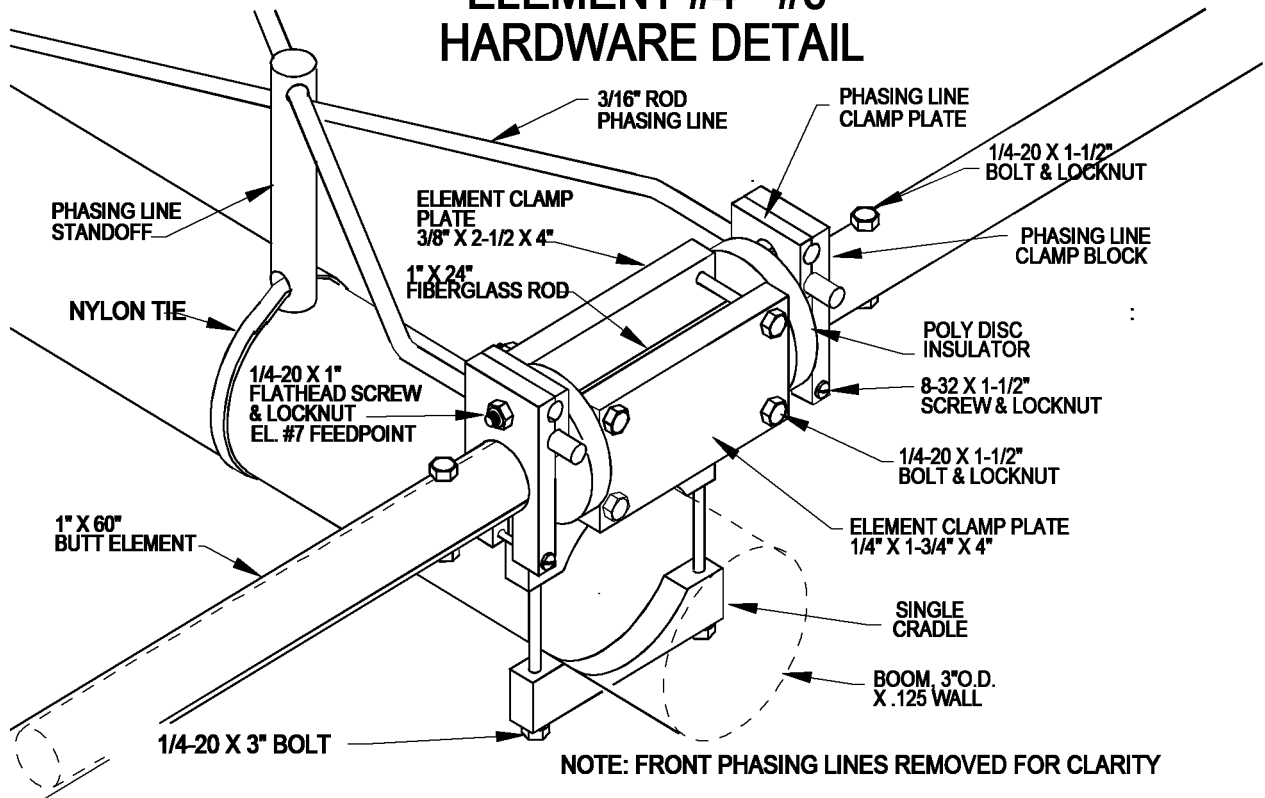

7&10-30LP8 ASSEMBLY DETAILS

ELEMENT #7 HARDWARE DETAIL

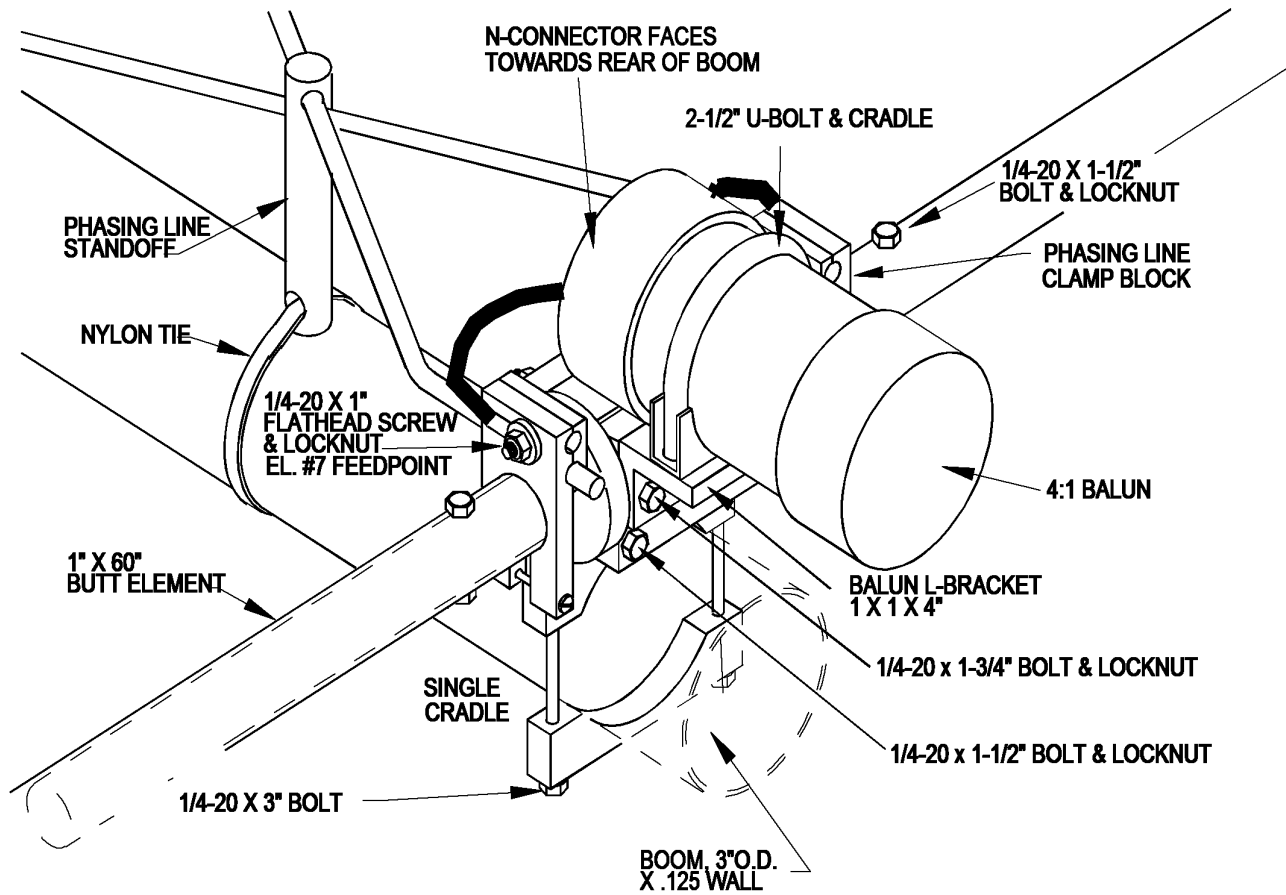

ELEMENT #8 HARDWARE DETAIL

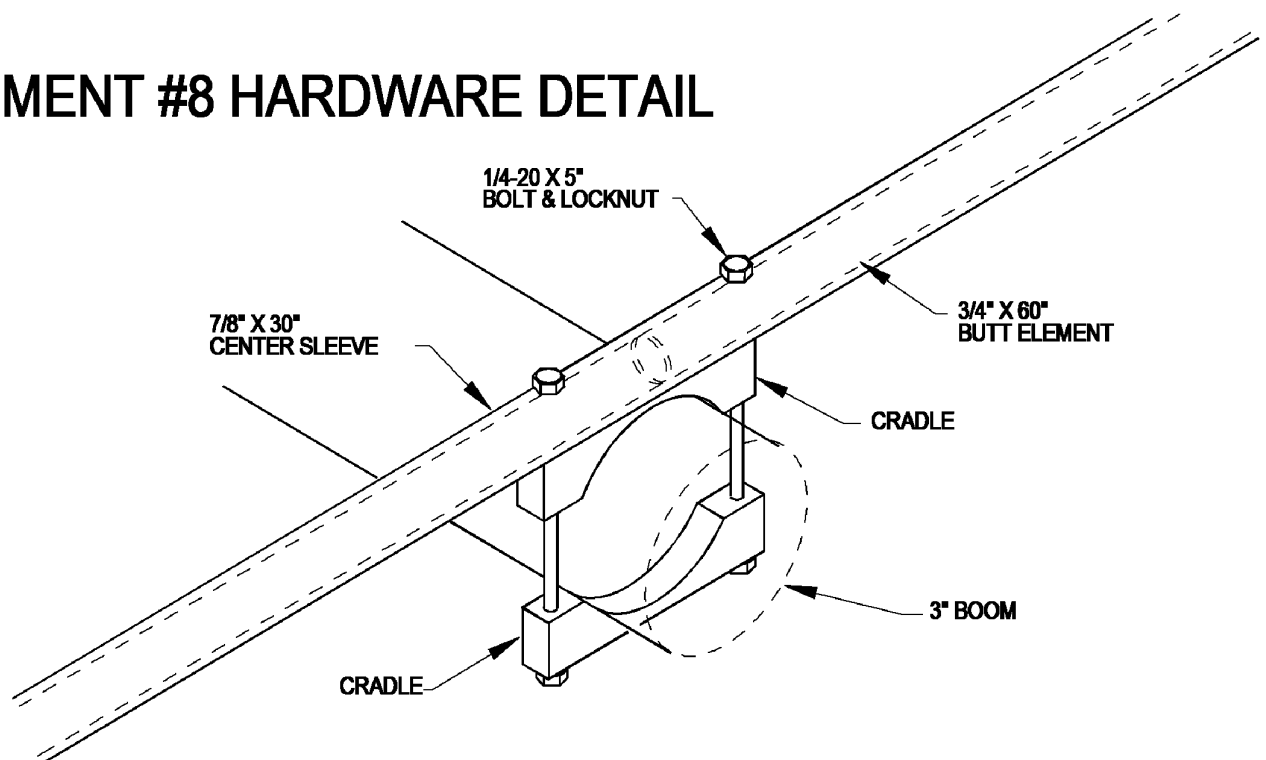

GENERIC COMPRESSION CLAMP DETAIL

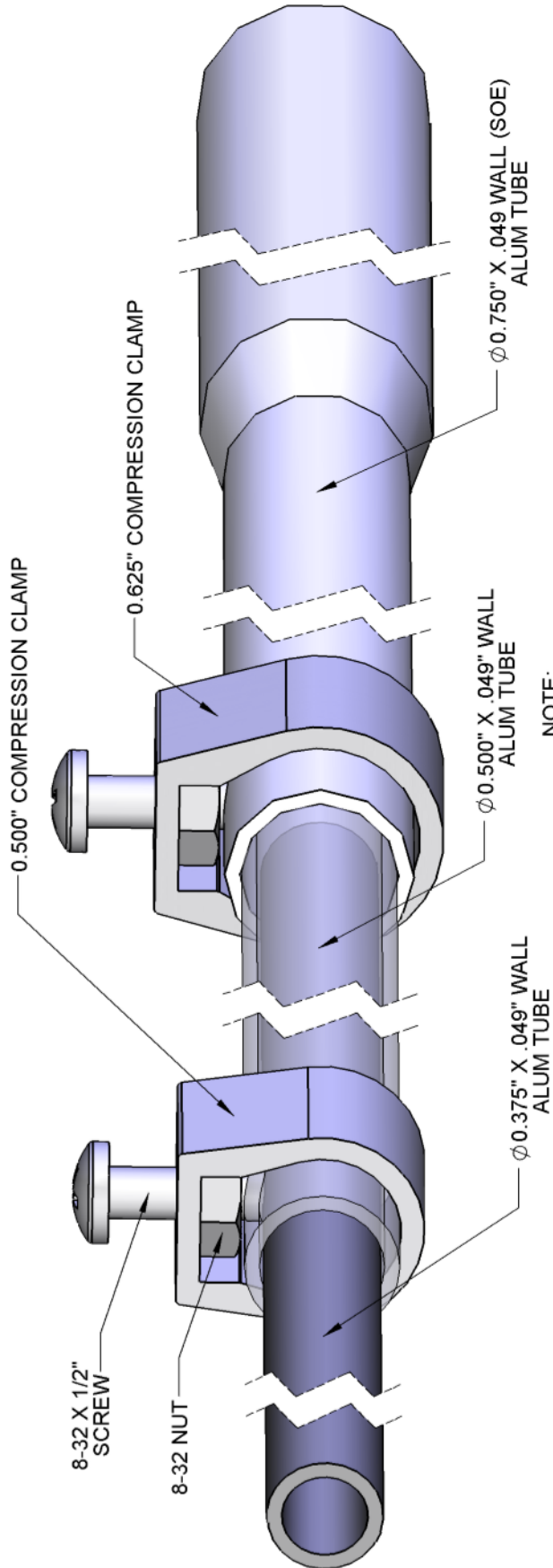

NOTE:
TUBES SHOWN TRANSPARENT
TO SHOW MORE DETAIL

NOTE:
Generic layout to show
how compression clamps work.
Your antenna may have one or the other
or may even have both compression
clamp sizes.

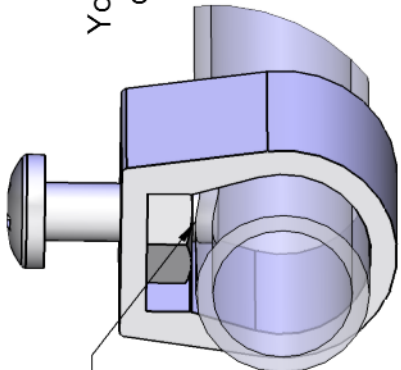

NOTE:
8-32 X 1/2" SCREW
PRESSES ON INNER TUBE

NOTE: INSIDE TUBE NOT SHOWN FOR CLARITY

7&10-30LP8 PARTS & HARDWARE

DESCRIPTION	QTY
Boom section, 3 x .125 x 180" swaged.....	1
Boom section, 3 x .125 x 180" straight	1
Sleeve, Director 7/8x.058x30	1
Sleeve, 1-3/8 x .058 x 23-13/16"	2
Sleeve, 1-1/8 x .058 x 23-13/16"	4
Element, 1-1/2 x .058 x 60" SOE,	2
Element, 1-1/4 x .058 x 60" SOE 1/4" hole.....	4
Element, 1-1/4 x .058 x 60 SOE	2
Element, 1.0 x .058 x 60 SOE	6
Element, 1.0 x .058 x 60" SOE 1/4" hole	8
Element, 3/4 x .049 x 60" SOE	6
Element, 3/4 x .049 x 60" SOE 1/4" hole.....	2
Element tip, 3/4 x .049 x 73.00"	2
Element tip, 3/4 x .049 x 62.25"	2
Element tip, 3/4 x .049 x 38.50"	2
Element tip, 3/4 x .049 x 22.5"	2
Element tip, 1/2 x .049 x 67.0"	2
Element tip, 1/2 x .049 x 62.50"	2
Element tip, 1/2 x .049 x 40.25"	2
Element tip, 1/2 x .049 x 24.5"	2
Log phasing rod, 3/16 x 83.75"	2
Log phasing rod, 3/16 x 72.375"	2
Log phasing rod, 3/16 x 59.25"	2
Log phasing rod, 3/16 x 48.5"	2
Log phasing rod, 3/16 x 41.0"	2
Log phasing rod, 3/16 x 35.0"	2
Linear loading rod 3/16 x 144" alum. rod	2
Linear loading rod 3/16 x 135" alum. Rod.....	4
Fiberglass rod insulator, 1-1/4 x 24"	1
Fiberglass rod insulator, 1 x 24"	2
Fiberglass rod insulator, 7/8 x 29.75"	4
Vertical support post, SQ. tube, 3/4 sq. x .125 x 11" alum	1
Boom to mast plate, 8 x 8 x 1/4" alum.	1
Balun, 4:1 ferrite core, 3 kW (FGBL1200)	1
Coil #10 AWG, 16 Turn.....	1

ELEMENT OVERHEAD SUPPORT UPGRADE	QTY
Support Post, LL, 1" X 1" X 24" (M2AVR0050).....	1
Element Overhead Support Clamp.....	2
Element Overhead Support Line, HPTG1200 x 30'	1
Turnbuckle, 1/4 X 5-1/4", Hook and Eye	2
Cable Eye, 6/16"	2
Wire Clip, 1/8"	4
Bolt, 1/4-20 x 3-1/2"	2
Locknut, 1/4-20,ss.....	2
Nut, 1/4-20,ss.....	2
Screw, 8-32 x 1-1/2", Pan Head Phil,ss.....	2
Locknut, 8-32,ss.....	2

7&10-30LP8 PARTS & HARDWARE

IN HARDWARE BOX

Element mounting plate, 1/2 x 3 x 6", .625 radius, alum	2
Element mounting plate, 1/2 x 3 x 6", .500 radius, alum	4
Small element mounting plate, 1/2 x 2-1/2 x 4" alum.	4
Small element mounting cap, 1/4 x 1-3/4 x 4" alum.	4
Cradle 3.0 LD, 1/2 x 1.0 x 4" alum.	12
Phase line clamp, 3/8 x 1-3/4 x 2-5/8" with 1-1/2" hole	2
Phase line clamp, 3/8 x 1-1/2 x 2-7/16" with 1-1/4" hole	4
Phase line clamp, 3/8 x 1-1/4 x 2-3/16" with 1" hole	8
Phase line clamp cap, 1/4 x 3/4 x 1-1/4"	14
Poly Disc insulator, 3/8 x 2" polyethylene, 1-1/4" hole	2
Poly Disc insulator, 3/8 x 2" polyethylene, 1" hole.....	4
Poly Disc insulator, 3/8 x 2" polyethylene, 7/8" hole	8
Linear loading insulator, 1/2 x 1-1/2" Polyethylene, .201 hole	6
Splice Block, linear loading, .25 x .5 x 1"	2
Stepped insulator, 3/4 x 1-1/2" Polyethylene, .201 hole.....	2
Phase line standoff, 3/4 x 3.0" Delrin, Machined	6
ABS LL support insulator, 1/4 x 1 x 6" Black ABS plastic	2
Linear loading dual support arm, .375 x 1.5 x 5.75" 1" hole	2
Linear loading stabilizer support arm, 1" hole, Mach alum	2
Linear loading support arm, .25 x 1 x 3.875, alum. 3/4 and 1/2" hole	4
Linear loading support arm, .25 x .75 x 3.875, alum. 1/2" holes"	2
Linear loading shorting bar, 1/4 x 3/4 x 5.875"	4
Strain relief, 1/2 x 1/2 blk delrin	2
Turnbuckle plate, 2 x 5 x 3/16"	1
Balun Bracket, 1 x 1 x 4"	1
Eyebolts, 3/8" x 6"	2
Turnbuckles, 3/8" hook and eye	2
Support rope, 5/16 x 30 ft. Dacron,	1
U-bolt, 3"	3
U-bolt, Heavy Duty, 2", 3/8	4
U-bolt, standard 2"	1
U-bolt, 2-1/2"	1
5/8" Compression clamp	8
Turnbuckle, hook and eye, 1/4"	2
Cable eyes, 3/16"	2
Cable clips, 3/16"	6
HPTG-1200 Phillistran cable, 36"	2
Nylon ties, large 14.5" black	10
Assembly manual	1
Zinc Paste (Penetrox, Noalox or equivalent) container	2

7&10-30LP8 PARTS & HARDWARE

HARDWARE BAG #1

Nut, 3/8-16 stainless	14
Lock washer, 3/8" split ring stainless	14
Nut, 5/6-18, stainless	4
Lock washer, 5/16" split ring, stainless	4

BAG #2

Bolt, 1/4-20 x 5" stainless	2
Bolt, 1/4-20 x 3-1/2" stainless	4
Bolt, 1/4-20 x 3" stainless	12
Bolt, 1/4-20 x 2-3/4" stainless	8
Bolt, 1/4-20 x 2-1/2" stainless	16
Bolt, 1/4-20 x 2.0" stainless	2
Bolt, 1/4-20 x 1-3/4" stainless	6
Bolt, 1/4-20 x 1-1/2" stainless	22
Screw, 1/4-20 x 1" countersunk, flathead, stainless	14
Nut, 1/4-20 locking, stainless	70
Nut, 1/4-20, plain, ss	2

BAG #3

Screw, 8-32 x 2" panhead stainless	2
Screw, 8-32 x 1-3/4" panhead, stainless	8
Screw, 8-32 x 1-1/2" panhead, stainless	28
Screw, 8-32 x 1-1/4" panhead, stainless	34
Screw, 8-32 x 1.0" panhead, stainless	8
Screw, 8-32 x 7/8" panhead, stainless	10
Screw, 8-32 x 1/2" panhead, stainless	8
Nut, 8-32 locking, stainless	100
Nut, 8-32 stainless	8
Set screw, 8-32 x 1/4 stainless	15
Shaft retainer, 3/16 stainless	15
Push tube 3/8 x 3" alum.	1
Allen wrench 5/64"	1

Carefully designed and manufactured by:

M² ANTENNA SYSTEMS, INC.

4402 N. Selland Ave.
Fresno, CA 93711
(559) 432-8873 Fax: 432-3059

www.m2inc.com Email: sales@m2inc.com

7&10-30LP8 VSWR

